

ELEVATION VIEWED FROM INSIDE

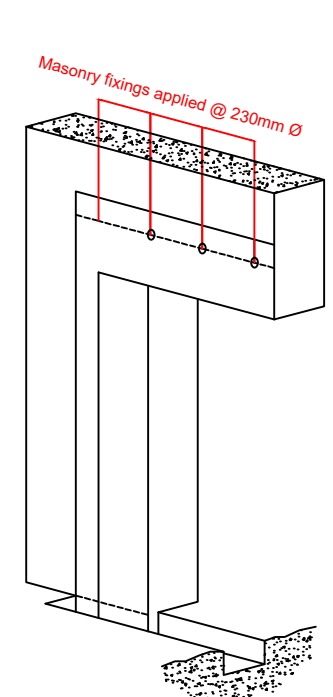

R.C. LINTEL

SUITABLE MASONRY FIXINGS ABLE TO WITHSTAND LOAD TO BE USED

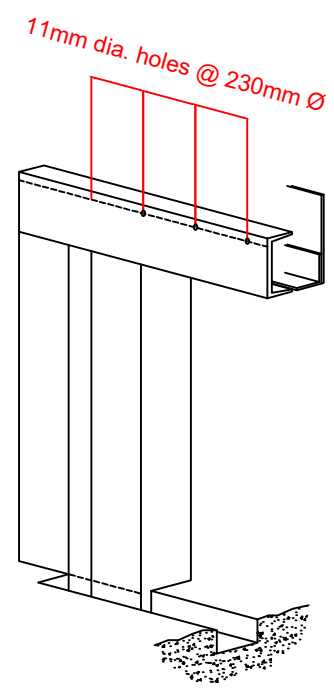

R.S. CHANNEL LINTEL

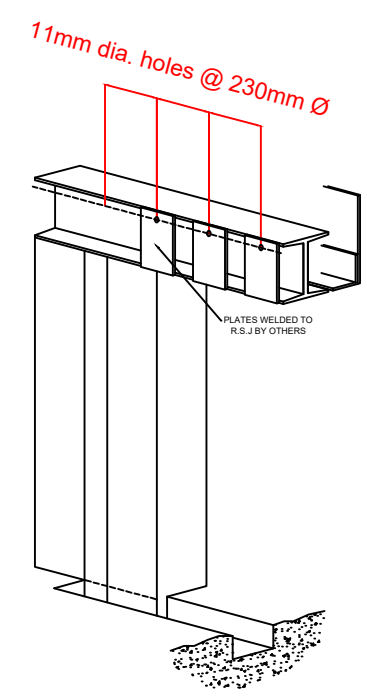

R.S. JOIST LINTEL

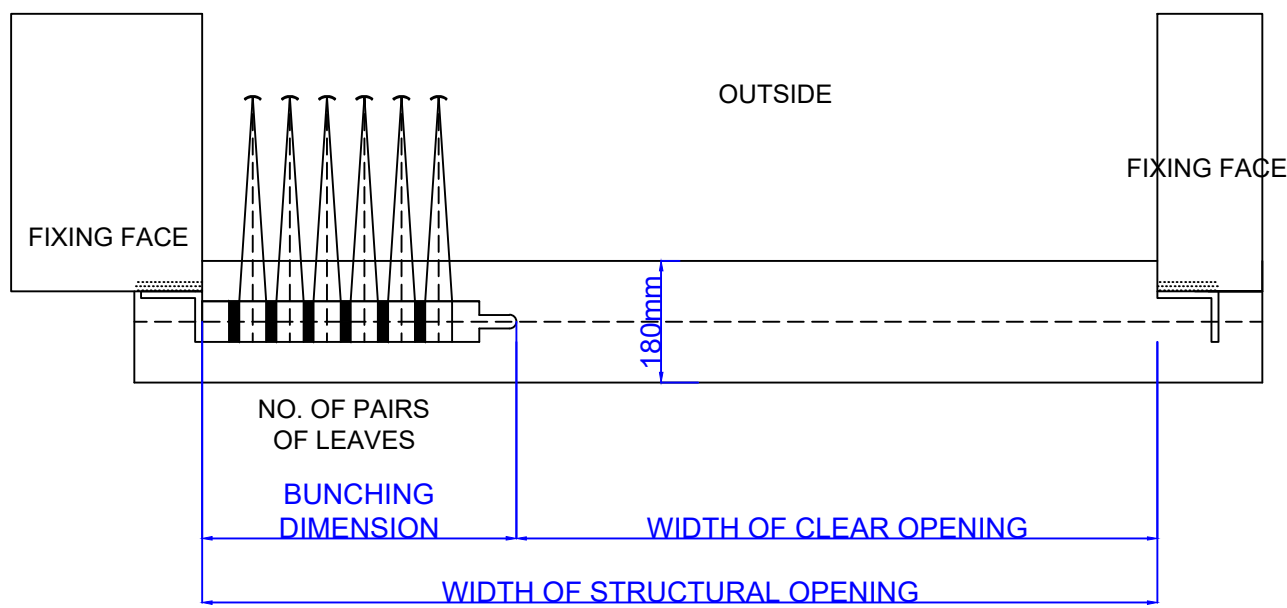
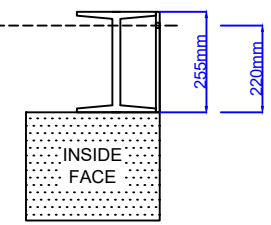
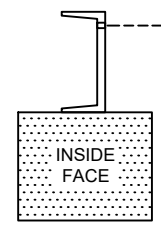

PLAN VIEW

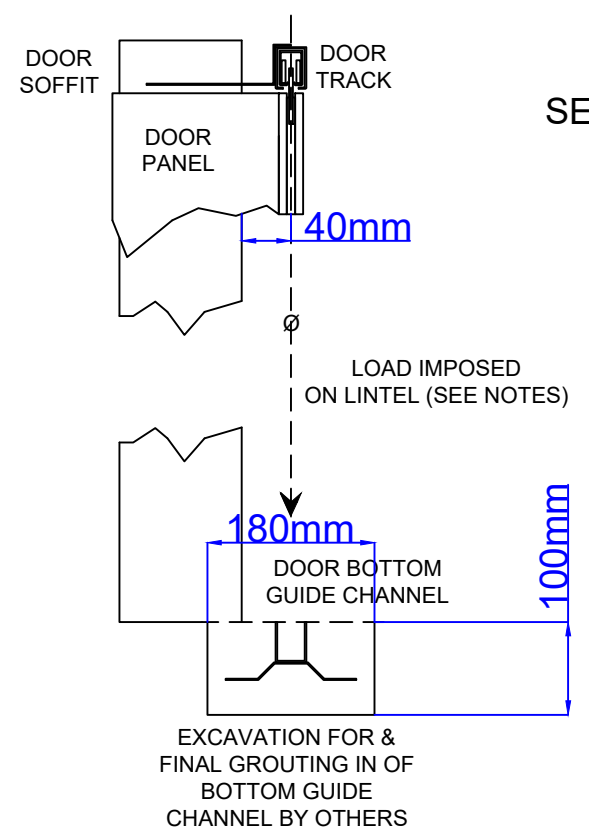

SECTIONAL VIEW

WESSEX INDUSTRIAL DOORS
(YEOVIL) LTD

WID SLIDING SHUTTER TYPE HG ARRANGEMENT 3 LEFT HAND, MANUALLY OPERATED

WID-HGL003

Location:		Architect/Contractor:	
Order no.:		Scale: NTS	
Drawn By: TIW	Checked By:	Approved By:	
Date: 22/02/2023			

Important notes:

- Dimensions**- All dimensions shown in millimetres.
 - Door**- Door panels, track, soffit and bottom guide channel by WID.
 - Structure**- All other materials and work to be provided by others. ALL FIXING FACES MUST BE FLUSH AND IN THE SAME VERTICAL PLANE AND ARE INDICATED AS THUS
- The lintel must be suitably tied into the structure to resist any over-turning movement and of adequate size to ensure the top track does not deflect more than 13mm under a moving load of 36.7kg per square meter of door area in the direction and position of the arrow shown in the sectional view.
- Fixing**- Suitable masonry fixings to withstand load to be used. When steel section lintels are used 11mm dia holes must be drilled. Fixings supplied by WID.
- SCALE AND MEASURE INCLUDED ON SAMPLE AS REFERENCE.
SUBJECT TO CHANGE BASED ON INSTALLATION AREA.

TOTAL NUMBER OF EQUAL SPACES FOR BOLT FIXINGS RELATED TO DIMENSION (W)

	1350	1940	2530	3120	3710	4300	4890	5480	6075	6665	7255	7845
(H)	1	2	3	3	4	5	5	6	6	8	8	9
	1	1	2	3	3	4	5	6	6	7	7	8
	1	1	2	2	3	4	4	5	6	6	7	8
	1	1	2	2	3	4	4	5	5	6	6	7